

PARTS CENTRAL

EDITION
39

> ONE STOP TO KEEP YOU MOVING.

> FREE

Visit www.alliancetruckparts.com.au/Parts-Central
for these special offers and more!

AIR BAG – A GREAT ALTERNATIVE TO THE GENUINE FREIGHTLINER AIR BAG.

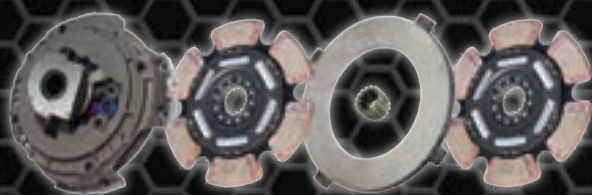

**NEW from
Alliance.**

**HDD (HEAVY DUTY DAMPER) CLUTCH
ASSEMBLY – NEW AND IMPROVED.**

More details on pages 5 and 6.

INSIDE:

> Air Filters
> Coolers
> Gauges

> Lighting
> Clutches
> Cleaning

> Air Bags
> Accessories
> and more...

SAF-HOLLAND ENGINEERING YOUR ROAD TO SUCCESS.



Holland 50mm Kingpin With Bolts

Q HLD 662101609K

\$110



210kN

Complete with:

- 1 x Holland 50mm kingpin
- 1 x Holland bolt set (8 x M14)

Holland 90mm Kingpin With Bolts

Q HLD KPB51042BK

\$200



260kN

Complete with:

- 1 x Holland 90mm kingpin
- 1 x Holland kingpin bolt set (8 x M14)

Holland FW351 Poly Bush and Pin Kit

Polyurethane foot bushes complete with foot pins and securing bolts/nuts.

Suits: Holland turntable models FW351 & FW331
Q HLD RK06356P

\$108



Great Value.

THE ALL-IN-ONE REBUILD KIT FOR HUB ASSEMBLIES.

An all-inclusive rebuild kit that has everything needed for servicing the PreSet wheel-end.



Includes Replacement Hubcap for Steer.



Front Steer Axles

FF Front Steer Axle

Complete rebuild kit	Q SKF FFSK1AU
Scotseal PlusXL	35058
Inner half stand bearing set	Set 427
Outer half stand bearing set	Set 428
Scotseal RF oil bath hubcap	1612
Spacer	Included with kit

\$220

FL Front Steer Axle

Complete rebuild kit	Q SKF FLSK1AU
Scotseal PlusXL	43761
Inner half stand bearing set	Set 445
Outer half stand bearing set	Set 446
Scotseal RF oil bath hubcap	1644
Spacer	Included with kit

\$230

Trailer Axles

TN Trailer Axle

Complete rebuild kit (oil bath)	Q SKF TNSK1AU
Scotseal PlusXL	46300
Inner half stand bearing set	Set 431
Outer half stand bearing set	Set 427
Spacer	Included with kit

\$215

TP Trailer Axle

Complete rebuild kit (oil bath)	Q SKF TPSK1AU
Scotseal PlusXL	42627
Inner half stand bearing set	Set 432
Outer half stand bearing set	Set 432
Spacer	Included with kit

\$335

Drive Axles

R Drive Axle - Long and Short Barrel

Complete rebuild kit (low profile seal)	Q SKF RDSK1AU
Scotseal PlusXL	47691
Inner half stand bearing set	Set 429
Outer half stand bearing set	Set 430
Spacer	Included with kit

\$300

AIR FILTERS.

Hino 1780178020

Suits: 300 series 414 & 614

Q DN P849069

\$60

Hino 1780178110

Suits: 300 series Euro 5 excl. 616 & 616 Hybrid

Q DN P634614

\$55

Hino 1780178040

Suits: 300 series 414 & 614

Q DN P849110

\$73

Hino 1780178080

Suits: 300 series Euro 5 - 616 & 616 Hybrid

Q DN P630752

\$105



DON'T JUST REBUILD. UPGRADE WITH HORTON.



Upgrade your Horton DMA-2S fan clutch to the latest Heavy Duty Outback specification.

Upgrade Supa Kit

Suits: Argosy DD15 & ISX,
Coronado DD15

Q HOR F25032

\$1800



DMA-2S Outback Fan Clutch Assembly

Suits: Argosy DD15
Q HOR FDMA915032S

\$2700



L.E.D. Side Marker Lamp

- Multivolt (8-28V DC)
- Fully sealed against dust and moisture to IP6K6 and IP6K7
- ADR 45/1 compliance

Q HAL 2053

\$19.50

Colours: Red and Amber



PVC Electrical Insulation Tape – Black, 20m

- Tape thickness: 0.145mm
- Flame retardant PVC electrical insulation tape
- Complies with British standards BS3924 31/90Tp, BS3110, BS3887 (1985) Part 2 Category 1 and IEC 454-3-1

Q HAL 8322

\$3.30



Connector Relay Suits 4 + 5 Pin

Sturdy plastic casing, supplied with 5 blade terminals

Suits: 4 and 5 pin relays with 6.3mm and 2.8mm flat pin connectors

Q HAL 4973

\$6.95



178mm H4 Halogen High/Low Beam Insert

Semi-sealed headlamp with front position lamp globe holder and sealing boot

Compliance: ADR 46/00, ADR 49/00

Q HAL 1058

\$57



7 Pole Socket – Metal

Metal housing with securing cap locks plug in position

Load: 20A at 12V (total); 10A at 24V (total)

Q HAL 4901

\$14



Exhaust Clamp Flat 5" – 127mm Z/P

Q NMC 0161CZ127F

\$9



GENUINE BENDIX BRAKE VALVES.



R12 Trailer Relay Valve

Q KNB 102277

\$70



E6 Foot Valve

Q BW 286171N

\$77

SR2 Trailer Spring Brake Valve

Q KNB K033128

\$120

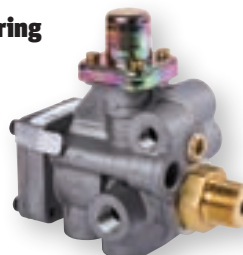

D2 Governor Valve

Q KNB 275707N

\$66



**Designed with the truck driver in mind.
Compact, lightweight and efficient.**



CF11 Portable Fridge/Freezer

- Extremely compact, super-slim design
- 12 or 24V DC, 100-240V AC
- L.E.D. interior light and digital display
- Adjustable shoulder strap
- Two integrated drink holders

Q WAE CF11
\$529



CFX 28.2L Fridge or Freezer

- Efficient deep freezing down to -22°C
- Easy temperature set between 10°C and -18°C
- Superbly quiet performance
- USB port for charging devices

Q WAE CFX28
\$825



**15.5" Heavy Duty Advantage Clutch
2" 10 Spline 2050Lb.Ft.**

Q ETN 308935529
\$1070



GEN 2 ECA Kit Heavy

Q ETN K4252
\$1700

**15.5" Heavy Duty Advantage Clutch
2" 14 Spline 2050Lb.Ft.**

Q ETN 308938556
\$1970

Cable Tie 7.5 x 360mm (100 pcs)

- UV stabilised cable ties in black nylon (V2-UL 94)
- For external applications
- Resistant to temperatures of -20°C to +80°C
- Resistant to solvents and reagents, oils and petrol
- Quality Italian made product

Q GPN GP56475360
\$19



King Pin Kit Ezi Steer FG941

Low friction bushings help reduce steering effort and provide longer life.

Suits: FG941 Front Axle

Q TDA R201309

\$249



Genuine Meritor Differential Oil Filter RT Series

Q TDA A3380W1687

\$22



Rechargeable L.E.D. Head Lamps

120LM L.E.D.

Q NAV 71424

\$53

- Detachable with integrated magnet, 120 lumens
- Lightweight 163g



250LM L.E.D.

Q NAV 71426

\$135

- Motion activated sensor, detachable with integrated magnet
- Powerful spot beam/flood light



Inspection Lamps



The Features:

- Glow in the dark faces for easy location
- IP65 dust and water resistant
- 180° rotating bracket with powerful magnet
- 2.5 hours continuous use

500LM LED

Q NAV 71462

\$135

200LM LED

Q NAV 71460

\$70



The offers presented are subject to stock availability during the promotion period and are available at participating dealerships only. Participation can be determined by calling 1300 323 722 or by calling your nearest dealership. Parts listed may be VIN specific, parts advertised have been identified to suit the majority of the models specified. Part numbers should be checked against the VIN to ensure suitability. For assistance, please contact your nearest participating Daimler Truck & Bus dealership prior to purchase. Prices within this promotion are recommended maximum selling prices including GST, excluding labour and fitment costs from a participating dealer. Prices will be valid during the promotion period stipulated at the front of this catalogue. All items have been included in good faith on the basis that they will be available during the promotion period. Photographs are for illustrative purposes only and may not represent actual products. We reserve the right to correct all printing errors. Where third party images and content appear, this has been done with the appropriate approval. Mercedes-Benz is a registered trademark of Daimler AG, Stuttgart Germany. Fuso is a registered trademark of Mitsubishi Fuso Truck and Bus Corporation, Japan. Freightliner and Alliance Truck Parts are registered trademarks of Daimler Trucks North America LCC, distributed by Daimler Truck and Bus Australia Pacific Pty Ltd. ABN 86 618 413 282.

THE ALLIANCE HEAVY DUTY DAMPER CLUTCH ASSEMBLY.



These Torque Performance clutches are built and designed specifically for the Australian market and include an HDD (heavy duty damper) design that provides a very strong clutch in the industry.

FEATURES AND BENEFITS:

- Clutch kit includes a spline saver design used to increase the strength and circumference of the input shaft
- Snap ring on the spline saver allows for an easy and even installation of clutch discs
- The HDD design is used in Alliance 2050, 2250 and 3000Lb.Ft. torque rated clutches
- All HD Alliance clutches include a clutch brake and clutch brake washer

15½ x 2 Easy Effort Clutch

Q ABP N25EA60289TPCBW

\$975



The 6-paddle, 6-spring design incorporates US-made springs that are longer and stronger than some other clutch disc springs.

ALSO AVAILABLE:

Easy Effort® Clutch Assembly

Q ABP N2520892525CBW*
(Equivalent to 20892525, 208935-529)

\$980

AutoSet Clutch® Assembly

Q ABP N2520970125CBW*
(Equivalent to 20970125, 209700-529)

\$1100

ASSEMBLIES INCLUDE:

- 15½ x 2, 10 spline
- 4000Lb plate load
- 2050Lb.Ft. torque rating
- 10" minimum flywheel ID
- Includes one piece clutch brake

CLUTCH 15½ x 2 4200/2250FP

Q ABP N2520893732CBW

\$1100

Features:

- 15½ x 2 Easy Effort clutch
- Two-plate
- 14 spline, 6-paddle/6-spring
- 4200 plate load/2250 torque
- Triple-zerk
- Includes spline saver

Clutch Installation Kit Fuller RT® Series Transmissions

Q ABP N25K2468

\$215



* Full warranty terms and exclusions available at your nearest participating Daimler Truck & Bus dealership

DEPENDABLE, AFFORDABLE AND AVAILABLE.



ALLIANCE AFX2 GREASE

Alliance AFX2 is a lithium complex grease formulated to provide improved oxidation, wear protection and corrosion resistance compared to conventional greases. It is specially designed for a variety of automotive applications, including wheel bearing and general chassis lubrication.

FEATURES AND BENEFITS:

- Resists to peak temperatures up to 180°C, while still ensuring efficient lubrication
- Efficiently protects metallic surfaces against corrosion
- Maintains consistency when operating under high loads and prolonged stress for longer periods compared to conventional greases

Grease
- 55kg Drum

Q ABP AFM4215055

\$600

Also available in:

- 450g
- 20kg
- 180kg



*Buy 1 x 55kg of grease and receive 12 x 450g cartridges FREE

ALLIANCE AIR BAG.

- A great alternative to genuine Freightliner air bag - QFI W013778536
- Air bags are a key component in levelling systems, allowing the truck and trailer level to be adjusted for easier loading and unloading

Air Bag/Air Spring

Q ABP N32019781

\$93

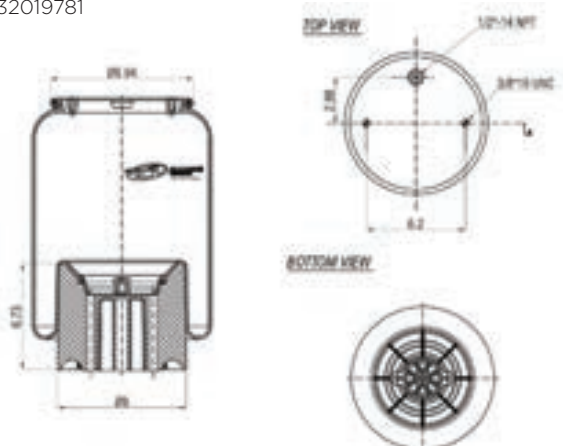

KEEP YOUR VEHICLE SHINY AND CLEAN.



Flow Through Pole - 2.5m
Q ABP RT22725

\$28

Poles fitted with Hi-Lo off valve aluminium tips for greater strength
Dimension: 150cm x 3.5cm x 3.5cm
Weight: 0.5kg



Quad 10" Brush Head
Q ABP RT357

\$20

Manufactured from a soft non-scratch fibre



Long Handle Dip and Wash Brush
Q ABP RT039

\$9.50

Manufactured from a soft non-scratch fibre



Prime Truck Wash 20L
Q ABP TWB20

\$45

- Heavy duty detergent
- Non-streak formula

Spin-On Air Dryer Cartridge

Extended desiccant cartridge life.

Suits: Bendix AD-SP/AD IS

Replaces: Bendix 5008414, Meritor R109994, R950011
Q ABP N10GR950011

\$39.50



20 Ton Hydraulic Bottle Jack - Regular

Q ABP N79523710

\$85

20 Ton Hydraulic Bottle Jack - Low-Boy

Q ABP N79523715

\$75

Dust Blower
KT-6M-1/4+5/1

Q ABP DB600PG86

\$30



Primary Fuel/Water Separator

Q ABP N122R50418

\$32

Premium Cab Blower Kit

Q ABP N42ACABBLWR

\$31



NEW TO ALLIANCE... L.E.D. 7" AND 9" DRIVING LAMPS.



7" L.E.D. Driving Lamps - Twin Pack
Q ABP TIR7

\$280



9" L.E.D. Driving Lamps - Twin Pack
Q ABP TIR9

\$350



Die-Cast Aluminium Body for Superior Strength

Adjustable Steel Bracket

Resistant to Extreme Off-Road Vibration



Latest TIR Optical Design for Greater Light Efficiency

IP68 100% Water and Dust Proof

Over Voltage Protection with EMC Compliance

Rubber Gasket

FEATURES:

- Focused optics for each L.E.D.
- Magnifying light intensity
- No light loss through reflectors
- Heavy duty vibration resistant



TIR7

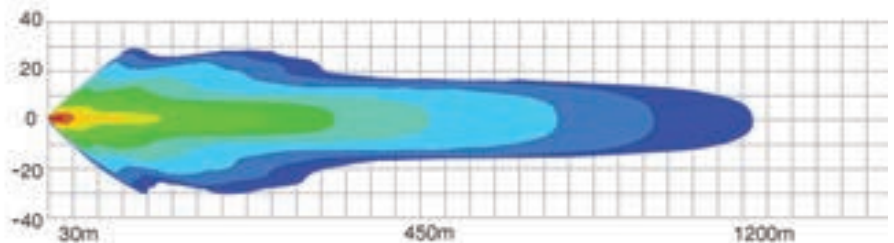

TIR9

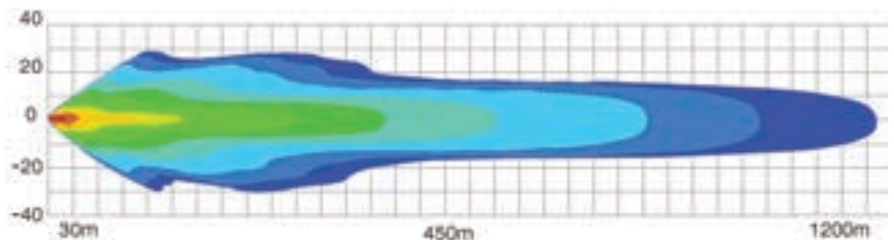

KEEPING YOU ON THE ROAD. FREIGHTLINER GENUINE PARTS.



Oil Temp Sender

Q FLC 06-23464-000

\$40



Roadranger Reverse Light Switch

Q POL 21465P

\$29



Flasher Unit Turn Signal

Suits: Coronado/
Late Century Class

Q TDM EP35

\$23



Indicator Switch

Suits: Late Coronado,
Argosy and Century Class

Q FLC A14-13495-005

\$180



GENUINE STEERING PARTS, ORIGINAL PERFORMANCE.

New Steering Gears

THP-60

Suits: Late Century Class

Q FLC 14-19710-000

\$1800



TAS65

Suits: Early Century Class

Q FLC 14-19390-000

\$2200

TAS65

Suits: Early Argosy

Q FLC 14-19388-000

\$2300

Steering Pumps

Q FLC 14-19401-000

\$600

Q FLC 14-19270-000

\$700



Draglinks

Suits: Coronado 114

Q FLC 14-18741-000

\$250

Q FLC 14-19103-000

\$350



Tie Rod Ends



FG 941

Q TDA R230068

\$85

Q TDA R230069

\$80

FG941 Late/ MFS-16

Q TDA R230072

Q TDA R230073

\$100 ea

Grey Leather Steering Wheel - 450mm

Q FLC A14-12612-001

\$450



Input Shaft Seal Kit

Q TRW TAS00001

\$34

Power Steering Filter

Q VML T1808G

\$40

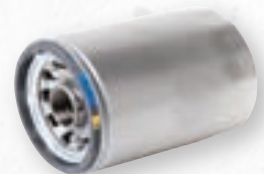

MANAGE YOUR REAL COST OF OWNERSHIP.



Radio Antenna

Suits: Coronado
Q FLC 22-48221-000

\$70



Brake Pedal Cover

Q BW 112911N

\$25



Cab Suspension Air Springs

Q FLC 18-29919-000

\$69

Q FLC 18-52651-000

\$95



CAB MOUNTS.

Isolator - Blue

Q BCD 276512

\$24



Isolator - Green

Q BCD 276511

\$35

GAUGES.

Speedometer

Suits: Argosy & Coronado
Q FLC A22-66348-120

\$250



Oil Temperature

Suits: Argosy & Coronado
Q FLC A22-66352-134

\$160



Isolator Front Motor Mount

Q BCD 289451

\$20



Wiper Arm

Suits: Coronado & Century Class
Q FLC A22-49253-002

\$120



Air Dryer On Tank

Q BW 800383

\$1000



Stud Wheel M22 x 1.5

Q CM 10001399

\$9.50



Surge Tank Cap

Q BHT W3678002

\$32



Surge Tank

Suits: Coronado/Late Century Class
Q FLC A05-25263-007

\$400



AIR FILTERS – SAVE MONEY, REDUCE DOWNTIME.



Original equipment Ultra Web® and Powercore™ air filters.

- Provide maximum protection from dust and dirt particles
- Reach optimal 99.97% efficiency much quicker than cellulose filters
- Last longer due to higher dust holding capacity of nanofiber technology

Silicone Hose 4" x 6"

Q FLF FRE10200001

\$36



Spring Loaded Clamp

Q BRZ B92240411FRU

\$9.60



Early Century Class and Argosy

Q DN DBA5069

\$120



Powercore™ Coronado, Late Century Class

Q FLC 03-36867-010

\$300



STOCK CLEARANCE... CUSTOM MADE FREIGHTLINER MERCHANDISE.

Freightliner Doona Cover Set

FREDOONA

Sleep in style with this Freightliner doona cover set consisting of a King Single doona cover and two pillow covers.



Freightliner Umbrella – Black

FREUMBRELLA



Rain or shine, protect yourself with this full fibreglass umbrella. It comes with a moulded rubber handle and safety runner to prevent pinched fingers. It's strong and won't rust.

T-Shirt – Dark Grey

FREVTEE



Trendy dark grey vintage style 180-190GSM poly/cotton with a customised metal badge on left hand side.

**GENUINE
FREIGHTLINER
MERCHANDISE.**

To view the catalogue and new additions, visit www.freightliner.com.au/Merchandise

To place an order or find out more, contact your nearest Dealer on 1300 323 722

**THESE PARTS AND MORE
ARE AVAILABLE FROM**



RGM MAINTENANCE - ROCKHAMPTON

(07) 4923 1000

1033 Bruce Highway,

North Rockhampton, QLD, 4702

www.rgmmaintenance.com.au



Subscribe
to the **FREE** must have trucker
magazine **Parts Central.**

www.alliancetruckparts.com.au/Parts-Central

